



Offsite Management Systems LLC

Consultant and Automation Solutions Provider
for Refinery Offsite Operations
*Redefining Excellence...*TM

Free Professional Webinar [REGISTER NOW](#)



Models based predictions of tank qualities reduce lab operational cost

When: April 23, 2015

Time: 10 -11 AM CST (Houston, USA)

Free Webinar but seats are limited.

[Register Now](#)



A typical refinery tankfarm has 100-300+ tanks to store both feed stocks and final products. The analyses of 15+ qualities of each of these tanks are required by refinery operations and activities such process units control and optimization system, refinery wide planning and scheduling system, Offline and online blend optimizers, final product certifications before dispatch to the customers.

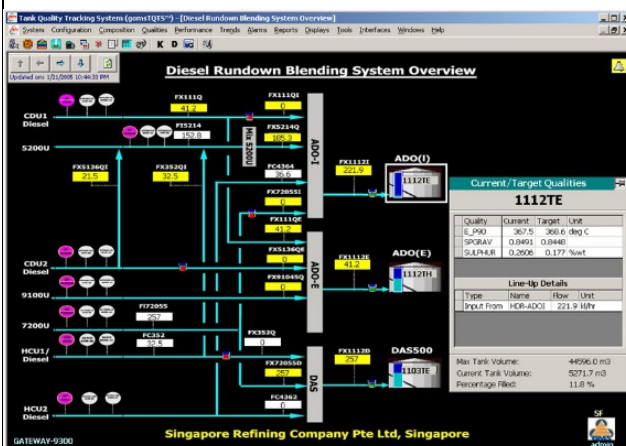

The traditional method of analyzing these tank qualities is to take infrequent samples and analyze them in the lab. This methodology is expensive, manpower intensive, time consuming and furthermore it delays the manufacturing processes due to lengthy analysis procedures. The information imparted during this webinar will discuss a model based online tanks quality tracking system how its implementation can save millions of dollars in the lab operational cost. It will also discuss the benefits of 2M\$+/year realized by a refinery in Singapore by its implementation for run-down open loop diesel, Jet Fuels and Kerosene Fuels blending systems.

What you will learn:

- A newly developed methodology for the Cost analysis of lab operations based on a typical refinery lab samples schedule and analysis for inline blending tanks qualities
- Discussion of features, benefits and case study for the implementation of online model based tanks quality tracking system at one of the Singaporean refineries

Who Should Attend:

The webinar is aimed at and is suitable for:

- Offsite Operations Managers
- Offsite Engineers / Operators
- Control System Engineers

Webinar Director:

Dr. Suresh Agrawal

President, Offsite Management Systems LLC

Dr. Agrawal has advanced degrees in Chemical Engineering from I.I.T's (India, USA). He has 30+ years of experience at senior technical / management positions with international companies and has successfully managed and executed many advanced refinery offsite operation automation projects in numerous countries. He has published and presented 30+ papers in international publications and conferences in the areas of refinery offsite operations automation. He has also acted as a consultant to a number of refining and process industries worldwide, and delivers training seminars in the areas of his expertise.



If you will like to review webinars in detail, please [click here](#).

Phone: 281-650-3707, Fax: 866-450-4035, Email: info@globaloms.com

[Register Now](#)

This promotional e-mail was sent to you because of your professional involvement and interest in the Oil & Gas refining Industry.

Copyright 2006-2014 Offsite Management Systems LLC

To unsubscribe from further course emails from OMS LLC, please send an [email](#) with subject line as "Unsubscribe"